

It is a metallic piece that protects materials from the adverse effects of electromagnetic noise sources. It provides electromagnetic shielding. It is attached to the casing of a device by means of the fan fixing screw (s). Ground the devices equipped with an EMC guard.

Ø172 mm type

Model no.	Surface treatment	Mass (g)
109-1036	Nickel-chrome plating (silver)	49

Representative fans model numbers	Dimensions of fans (mm)
109E47*	Ø172×25
109L17*	Ø172×51
9GV57*	
109E17*	
109E57*	
9SG57*	

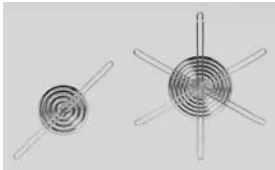
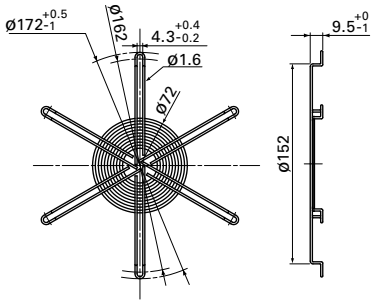

EMC guard

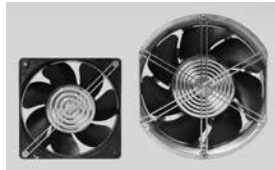

attached to a cooling fan